

# IOT HEART ATTACK DETECTION AND HEART RATE MONITOR

**Ankireddy Palli Akhila<sup>1</sup>, Gujjala Ankitha<sup>2</sup>, Pallapu Hemanth<sup>3</sup>,  
Chagalamarri Hussain Bi<sup>4</sup>, Mr.M.Narasimha Yadav<sup>5</sup>**

<sup>5</sup>Guide

Department Of Cse  
Tadipatri Engineering College,  
Tadipatri

## **Abstract:**

The IoT-based heart attack detection and heart rate tracking machine is designed to constantly screen someone's heart and body temperature and locate early signs and symptoms of coronary heart attack. The device combines a heart rate sensor and a DS18B20 temperature sensor connected to an Arduino Uno for real-time processing. The accumulated health data is displayed on a 16x2 LCD display screen for smooth monitoring. Additionally, it'll be sent to the healthcare company or property owner thru a Wi-Fi module for fast motion. In case of unusual readings, the device will sound an alarm via a buzzer and send an emergency alert through IoT connectivity that could offer timely scientific help. The device presents an effective and low-fee solution for non-stop coronary heart rate monitoring, especially for high-chance individuals.

**Keywords:** IoT-based health monitoring system, Remote patient monitoring, MAX3100 Biosensor Module, Arduino.

## **INTRODUCTION**

Global healthcare systems have faced unprecedented problems as a result of the COVID-19 pandemic, especially in managing the patient intake and minimizing the likelihood of virus transmission. Hospitals and medical facilities have been inundated by the growing need for resources, resulting in considerable pressure on medical personnel and infrastructure. This context has led to recommendations suggesting that individuals exhibiting mild COVID-19 symptoms should isolate at home instead of seeking hospital treatment. The implementation of remote patient monitoring has surfaced as a vital solution to these issues. Health monitoring systems utilizing Internet of Things (IoT) technology present an innovative method for managing patient care while lessening the strain on healthcare facilities. From the comfort of patients' homes, these devices enable continuous, real-time monitoring of vital indicators such as oxygen saturation, heart rate, and respiration rate. By delivering up-to-date health information to healthcare providers, remote monitoring solutions enhance the efficacy of patient care management. They permit early identification of health decline, which facilitates prompt medical interventions and decreases the frequency of hospital visits. Furthermore, by reducing the necessity for physical interactions between patients and healthcare professionals, these systems aid in lowering the risk of virus transmission, fostering a more secure healthcare setting. In light of the COVID-19 pandemic, this study investigates the role of Internet of Things-driven remote health monitoring systems. We will examine the technological aspects of these systems, how they affect the provision of healthcare, and any potential benefits they might offer for pandemic management.

## **RELATED WORK**

Mehmet Taştan, 2020 , This study offers a wearable Internet of Things (IoT)-based smart health monitoring device designed specifically for those with cardiovascular diseases. Wearable sensors are used by the system

to measure vital factors such as body temperature (BT), heart rate (HR), and heart rate variability (HRV). The gathered information is monitored remotely via an Android application, allowing continuous tracking without the necessity for frequent visits to healthcare facilities. By utilizing IoT technology, the system improves patient safety, reduces healthcare expenses, and ensures timely medical responses [1].

Md. Milon Islam, Ashikur Rahaman, Md. Rashedul Islam, 2019 The article introduces a healthcare monitoring system that leverages IoT to observe patients' vital signs, such as heartbeat and body temperature, alongside environmental measurements like CO and CO<sub>2</sub> concentrations. The system functions in real-time and promotes telemedicine by enabling remote monitoring in hospitals and healthcare centers. This innovation leads to more effective and accessible healthcare, lessening reliance on conventional face-to-face consultations [2].

Priyadharshini, B. Shunmugapriya, B. Paramasivan, J. Naskath, S. Preethi, R. Nivetha, and B. Shunmugapriya, 2020 An Internet of Things-enabled health monitoring system designed for the elderly and disabled is presented in this study. The device uses wearable sensors to track body temperature and heart rate, among other critical indications. It offers choices for remote monitoring, decreasing the frequency of hospital visits and reducing healthcare expenses. The system allows for timely medical interventions, enhancing the quality of life for those facing mobility or accessibility challenges [3].

Md. Rashedul Islam, Ashikur Rahaman, Md. Milon Islam, 2019 This paper showcases a smart healthcare monitoring system within an IoT framework, addressing the demand for portable healthcare solutions. The system captures essential health metrics, including heart rate and body temperature, while also assessing room conditions through sensors for CO, CO<sub>2</sub>, and temperature. Real-time data collection facilitates telemedicine applications, transitioning routine health evaluations from hospitals to home environments, thus alleviating healthcare burdens and improving patient convenience [4].

Rayan Elkhatib, Ahlam Salih, Mohamed Fadl, 2020 The study presents an interactive dashboard for tracking COVID-19 in Sudan, tackling the issues posed by conventional paper-based reporting. Developed using Tableau, the dashboard illustrates data trends and patterns for COVID-19 cases from March to September 2020. This tool equips health authorities and the public with a clear and comprehensive overview of the outbreak, supporting informed decision-making and efficient resource allocation [5].

## **EXISTING SYSTEM**

The existing Arduino-based system for monitoring the health of Covid-19 patients has several limitations, including inadequate connectivity due to the absence of integrated Wi-Fi or Bluetooth modules, as well as restricted processing and memory capabilities that hinder the management and storage of real-time data. Scalability poses a challenge, as traditional configurations struggle to monitor multiple patients simultaneously. Additionally, integrating data into current electronic health record (EHR) systems presents difficulties, and ensuring patient privacy and security with robust protective measures is complex. Other concerns include maintaining the accuracy of sensors amid environmental variability and creating a user-friendly interface.

## **Disadvantages**

Monitoring and transmitting data in real-time can pose difficulties because of processing constraints and possible latency problems, which can impact the system's responsiveness. Furthermore, these configurations lack scalability, making it challenging to observe numerous patients at once in larger healthcare environments.

## REQUIREMENT ANALYSIS

### Evaluation of the Rationale and Feasibility of the Proposed System

To reduce the risk of infection and improve patient care management, the objective is to develop an Internet of Things (IoT)-based health monitoring system that enables healthcare professionals to remotely monitor the vital signs of Covid-19 patients, including blood saturation, heart rate, pulse rate, and body temperature. The proposed IoT health monitoring solution is designed to facilitate continuous and accurate remote monitoring of Covid-19 patients' vital signs it makes use of a MAX3100 biosensor module to track blood saturation and heart rate, and a DS18B20 sensor to assess body temperature. A humidity sensor is also used to measure the humidity and room temperature. The system is powered by an ESP8266Arduino microcontroller, which handles the encoding and decoding of all incoming data before execution. Sensors are placed on the patients' fingers, and the collected data is transmitted to a smartphone for real-time visualization and remote monitoring by healthcare workers. This innovation allows healthcare professionals to oversee multiple patients concurrently, ensuring quick reactions and reducing the risk of infection through fewer physical interactions.

## PROPOSED SYSTEM

The proposed Internet of Things (IoT)-based health monitoring system is intended to provide remote vital sign tracking for COVID-19 patients, guaranteeing accurate and ongoing health monitoring. It features a DS18B20 sensor for measuring body temperature and a MAX3100 biosensor module for monitoring heart rate and blood oxygen saturation. A humidity sensor is also included to gauge the room's temperature and humidity levels. The core of the system is an ESP8266Arduino microcontroller, which processes and manages all incoming data prior to execution. The sensors are affixed to the patients' fingers, and the collected data is transmitted to a smartphone for real-time visualization and oversight by medical personnel. This technology allows healthcare providers to monitor multiple patients simultaneously, ensuring prompt interventions and minimizing the risk of infection by reducing the need for physical contact.

### Advantages:

The suggested health monitoring system utilizing IoT technology provides notable benefits, such as enabling remote observation, which allows healthcare providers to monitor numerous patients at once without the need for in-person contact, thereby minimizing the risk of infection.

## SELECTED METHODOLOGIES

To gather vital health data for effective patient monitoring, the proposed system integrates a number of sensors, including the DHT11 for recording room temperature and humidity, the DS18B20 for tracking body temperature, and the MAX30100 biosensor for measuring blood saturation and heart rate. The ESP32 Arduino is at the heart of this system; it processes sensor data and controls encoding and decoding to ensure accurate transmission.

With its web server functionality, the ESP32 utilizes the HTTP protocol to send live data to a web interface, allowing healthcare professionals to view patient information remotely on smartphones or computers. This capability for remote monitoring enables medical personnel to oversee multiple patients at once, reducing the need for physical contact and lowering the risk of infections, all while presenting data in a clear and user-friendly format.

## SYSTEM ARCHITECTURE

The ESP8266Arduino microcontroller is at the centre of the design of the suggested Internet of Things-based health monitoring system, as seen in Figure 1, which acts as the central processing and communication unit. The system incorporates various sensors, such as the DS18B20 for measuring body temperature, the MAX3100 biosensor for tracking heart rate and oxygen levels, as well as a humidity sensor for monitoring environmental conditions.

The microcontroller encodes and processes the data gathered by the sensors before wirelessly sending it to a paired smartphone. A user-friendly application on the smartphone provides real-time health metrics for remote observation by healthcare professionals.

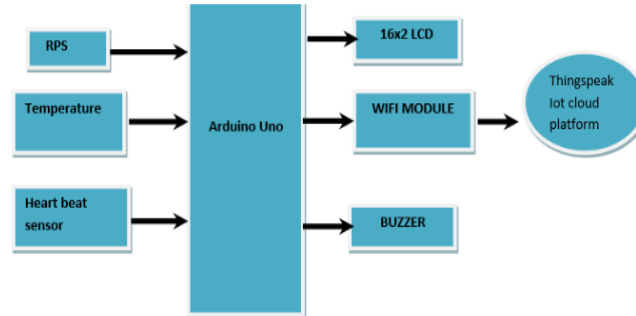
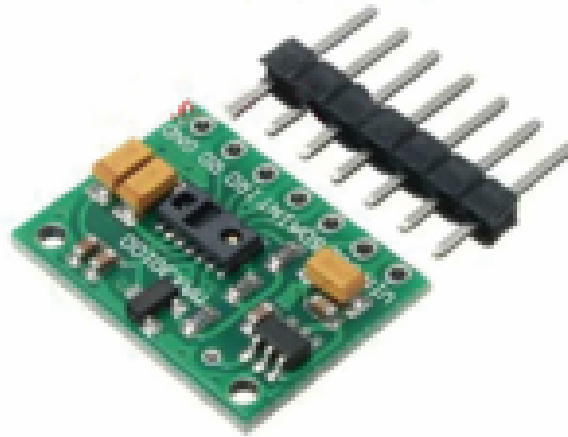

Fig 1

## SYSTEM MODULES

### MAX30100 Biosensor Module:



The MAX30100 module tracks blood oxygen saturation (SpO<sub>2</sub>) and heart rate by employing red and infrared LEDs along with a photodetector. The LEDs project light through the skin, and the photodetector detects the reflected light, which changes according to variations in blood volume. This information is analyzed to determine the levels of oxygen and heart rate.

### DS18B20 Temperature Sensor:



The DS18B20 sensor accurately measures body temperature and utilizes a 1-Wire interface. It delivers digital temperature readings, functions effectively across a broad range (-55°C to +125°C), and relays data directly to the ESP8266 microcontroller.

### DHT11 Temperature and Humidity Sensor:



The DHT11 sensor provides digital output after measuring temperature and humidity. It functions between 0 and 50°C in temperature and between 20 and 90% in humidity. In order to monitor the surrounding environment, it transmits data to the ESP8266.

### Arduino UNO:



One of Arduino's standard boards is the Arduino UNO. 'One' is what UNO means in Italian. The Arduino software's initial release was dubbed UNO. Additionally, it was Arduino's first USB board. It is regarded as a strong board that is utilized in many different tasks. The Arduino UNO board was created by Arduino.cc. The ATmega328P microprocessor serves as the foundation for the Arduino UNO. In contrast to other boards, like the Arduino Mega board, etc., it is simple to use. Shields, additional circuits, and digital and analog input/output (I/O) pins make up the board.

### Web Server:





The web server serves as the host for the user interface, enabling remote access to health information. It utilizes HTTP for data transmission to a smartphone or PC interface, allowing healthcare providers to observe patient vital signs in real-time.

## RESUL & DISCUSSION

The significance of the research is examined in this analysis section, particularly in light of the COVID-19 epidemic, which has placed an unprecedented strain on healthcare systems globally. Hospitals are severely overcrowded as a result of the pandemic because of the influx of virus-infected patients. In addition to overburdening healthcare facilities, this circumstance has made it extremely difficult to provide other patients with varying medical needs with the proper care. The demand for creative solutions that might assist hospitals in better managing their patient load has been brought to light by the strain on resources, including medical personnel, equipment, and space. The implementation of the proposed Internet of Things-based healthcare and health monitoring system is one possible solution to these problems. By using IoT technology, the solution can significantly reduce the strain for medical staff, allowing them to focus on other crucial responsibilities.

## GRAPH



Graph of Heart beat monitor a



Graph of Heart beat monitor b

## CONCLUSION

In summary, IoT-based remote health monitoring systems have become vital in managing patient care throughout the COVID-19 pandemic. These technologies help alleviate pressure on healthcare facilities by decreasing the need for face-to-face consultations and reducing overcrowding. By facilitating continuous and

real-time tracking of vital signs, they allow healthcare professionals to intervene promptly and enhance patient outcomes. Furthermore, remote monitoring diminishes the risk of virus transmission by limiting physical contact between patients and healthcare providers. However, challenges related to data privacy, system reliability, and accessibility for users need to be tackled. Future developments should aim at addressing these issues to improve the effectiveness of remote health monitoring. In general, these systems signify a significant advancement in optimizing healthcare delivery and maintaining safety during the pandemic.

**REFERENCES:**

- [1] S.N. Al-Humairi, M.H. Zainol, H. Razalli, L.B. Raya, M.I. Irsyad, Abdullah, et al., Conceptual Design: A Novel Covid-19 Smart AI Helmet, 2020.
- [2] M. N. Mohammed et al., "2019 novel Coronavirus disease (covid-19): Toward a novel design for disinfection robot to combat Coronavirus (covid-19) using IoT based technology", 2021 IEEE 12th Control and System Graduate Research Colloquium (ICSGRC), 2021.
- [3] L. Priyan, M. G. M. Johar, M. H. Alkawaz and R. A. A. Helmi, "Augmented reality-based COVID-19 SOP compliance: Social distancing monitoring and reporting system based on IOT", 2021 IEEE 12th Control and System Graduate Research Colloquium (ICSGRC), 2021
- [4] N. Z. Malika, M. G. Md Johar, M. H. Alkawaz, A. Iqbal Hajamydeen and L. Raya, "Temperature & humidity monitoring for poultry farms using IOT", 2022 IEEE 12th Symposium on Computer Applications & Industrial Electronics (ISCAIE), 2022
- [5] F. J. Adha, M. Gapar, Md Johar, M. H. Alkawaz, A. Iqbal Hajamydeen and L. Raya, "IoT based Conceptual Framework for Monitoring Poultry Farms", 2022 IEEE 12th Symposium on Computer Applications & Industrial Electronics (ISCAIE), 2022.
- [6] A. N. B. Hanif, S. N. S. Al-Humairi and R. J. Daud, "IoT -based: Design an autonomous bus with QR code communication system", 2021 IEEE International Conference on Automatic Control & Intelligent Systems (I2CACIS), 2021
- [7] S. P. Mariadass, S. Najah Saud Al-Humairi and R. J. Daud, "Design a portable solar mobile system with an IoT integration-based", 2021 IEEE 12th Control and System Graduate Research Colloquium (ICSGRC), 2021
- [8] S. K. Dey, M. M. Rahman, U. R. Siddiqi and A. Howlader, "Exploring Epidemiological Behavior of Novel Coronavirus Outbreak through the Development and Analysis of COVID-19 Daily Dataset in Bangladesh", medRxiv, vol. 2730, pp. 2020.06.30.20143909, 2020
- [9] J. Hua, G. Wang, M. Huang, S. Hua and S. Yang, "A Visual Approach for the SARS (Severe Acute Respiratory Syndrome) Outbreak Data Analysis", Int. J. Environ. Res. Public Health, vol. 17, no. 11, pp. 3973, Jun. 2020.
- [10] H. Florez and S. Singh, "Online dashboard and data analysis approach for assessing COVID-19 case and death data", F1000Research, vol. 9, pp. 570, 2020.